

SÚKROMNÁ ŠKOLA UMELECKÉHO PRIEMYSLU

Obhajoby PSP

15.12.2025

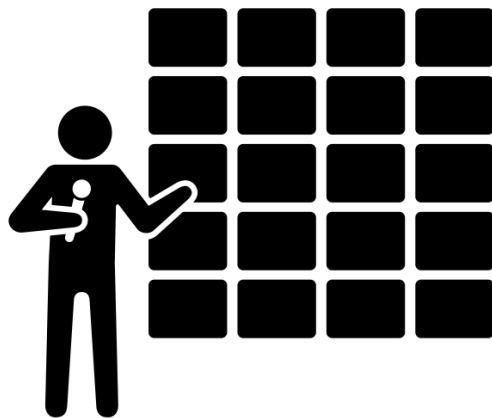

Meno: Libor

Priezvisko: Čimbora

Trieda: 4.B

Odbor: Fotografický dizajn

Autoportrait

MOODBOARD

SELF_

_PORTRAIT

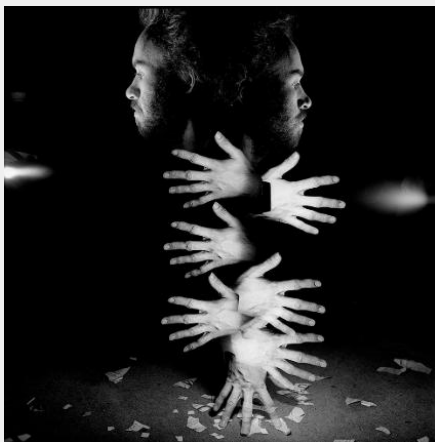
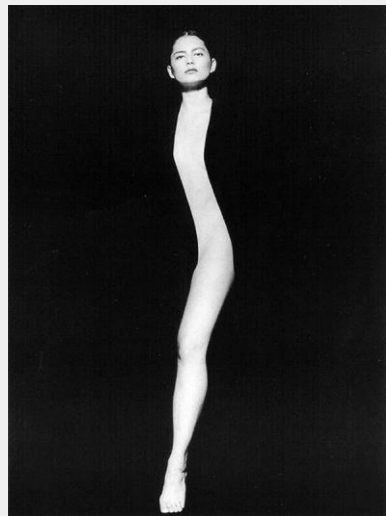
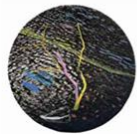
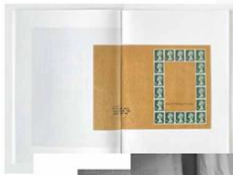

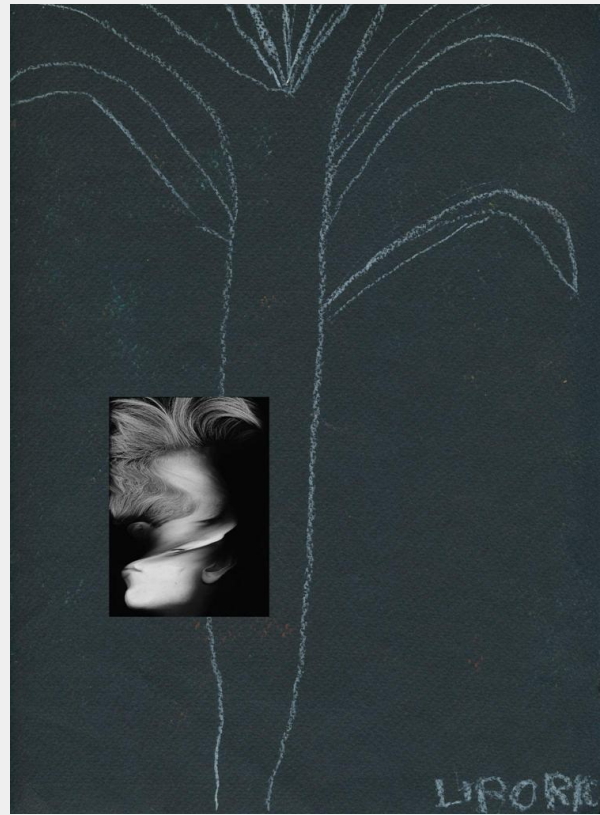
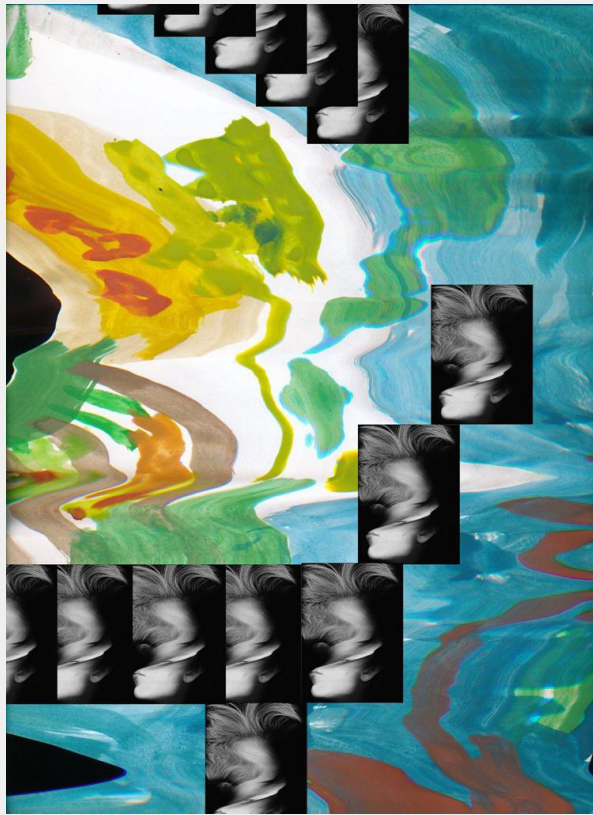









Lac

ŠK

PF

S

gra

nou

nej

čiat

L

knih

luj

ruč

čiat

lovi

je

ky,

opi

zac

neg

ban

tog

mit

iluz

pot

je

foti

chý

dog

pos

i

vad

pre

nej

bez

dol

zau

šir

mi

lic

bol

uk

vy

tos

úle

pr

sp

v

UZÁVIERKA — EXPOZIČNÉ ČASY A MOMENTY

(Viac o uzávierke pozri na str. 13 a 15).

T

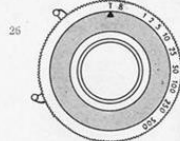

26

26 — Časy T a B: Pri postavení prstenca uzávierky na T bude po stlačení spúšte uzávierka otvorená potiaľ, kým spúšť druhý raz nestlačíme. Používa sa na dlhé expozície.

B

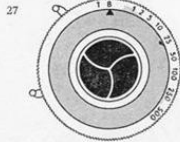

27

27 — Značka B má tú istú funkciu ako T, ale uvoľnením spúšte sa uzávierka hneď zatvorí. Osvedčí sa na kratšie „časy“. Kde niet značky T, použijeme B a špeciálnu drôtenú spúšť so zarážkou alebo fixovaním. Stupnica čísel na uzávierke predstavuje menovateľov zlomkov sekundy, ktorých čitateľ je vždy 1 — napr. 1/1, 1/10, 1/200 sekundy atď.

1 (1) 1 1 1 1 1
2 5 10 25

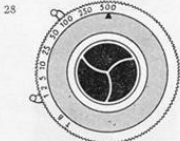

28

28 — Momenty — expozície od 1 do 1/25 sekundy. Tieto dlhšie osvity nepripúšťajú fotografovanie z ruky, treba použiť statív. Snímky pohybujúcich sa predmetov by boli tak isto rozmazané. 1/50 sekundy je už kratší osvit. Vystačíme s ním na ostré zachytenie väčšiny statických predloh (krajina, stojacie osoby, predmety atď.) už pri fotografovaní z ruky. Väčšinu záberov robíme pri 1/100 sekundy. Zachytime ostro aj deť s menším pohybom (hra detí a pod.) pri odstupe vyše 4 m. 1/250 sek. sa používa na väčšinu snímok živej tematiky. 1/500 sekundy je dostatočne krátky osvit na všetky ostatné bežné zábery (šport atď.) viac ako 2 m. 1/1000 sekundy je najkratší používaný osvit, ktorý slúži na ostré zachytenie veľmi rýchleho pohybu objektu v našej praxi. Majú ho štrbinové uzávierky.

1 1 1 1 1
50 100 250 500 1000

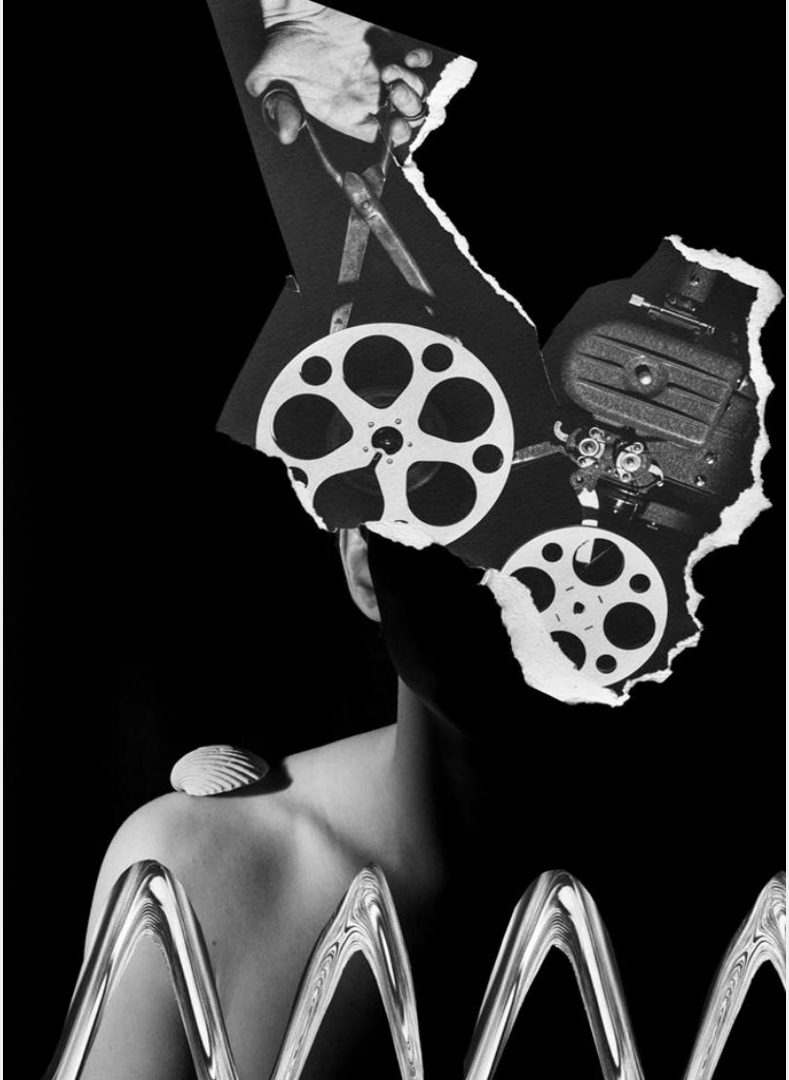

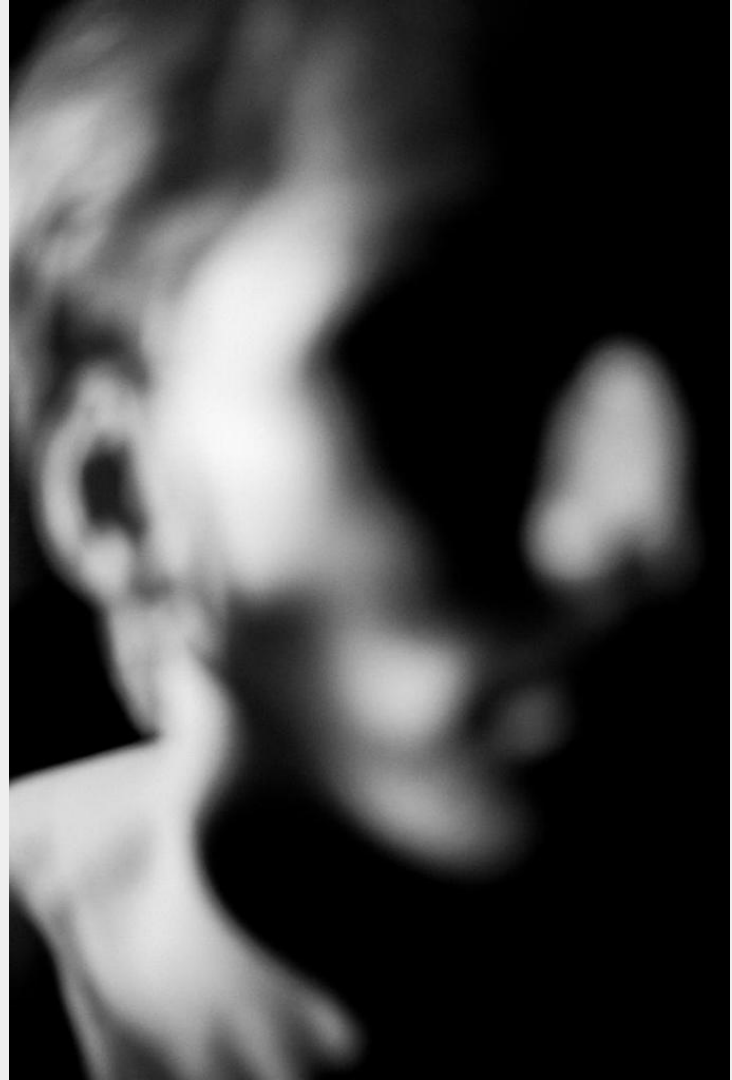



AUTOPORTRÉT

LIBOR ČIMBORA

4.B. FD

2025

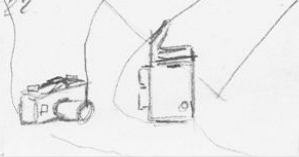
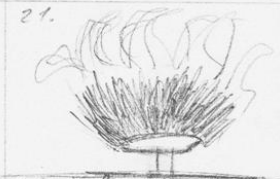
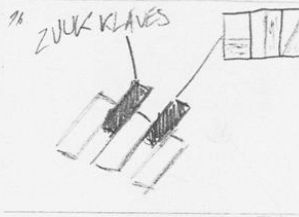
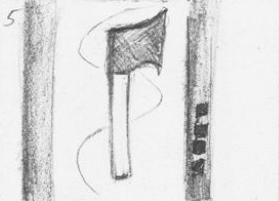
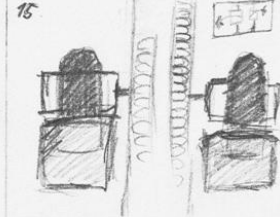
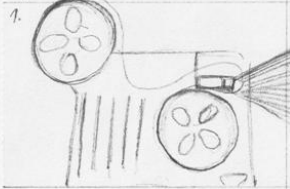



Univisium 3-perf

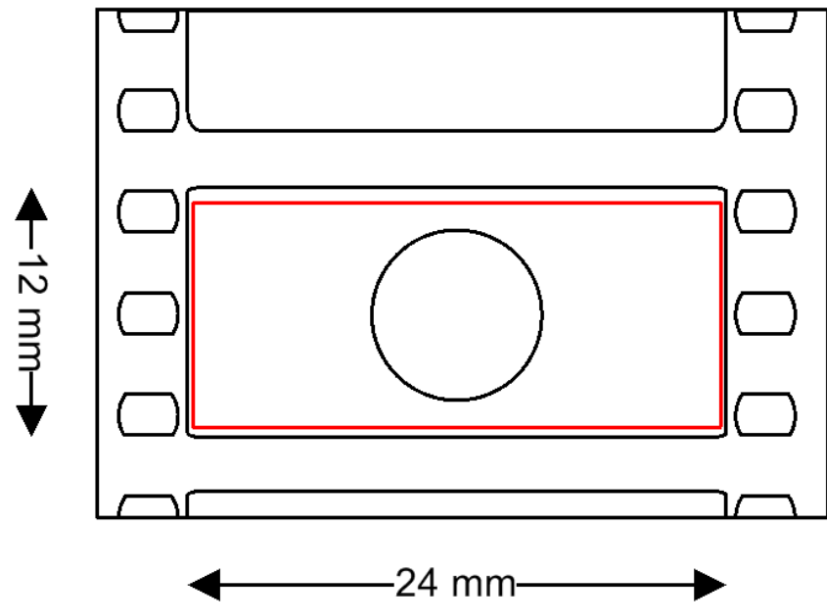



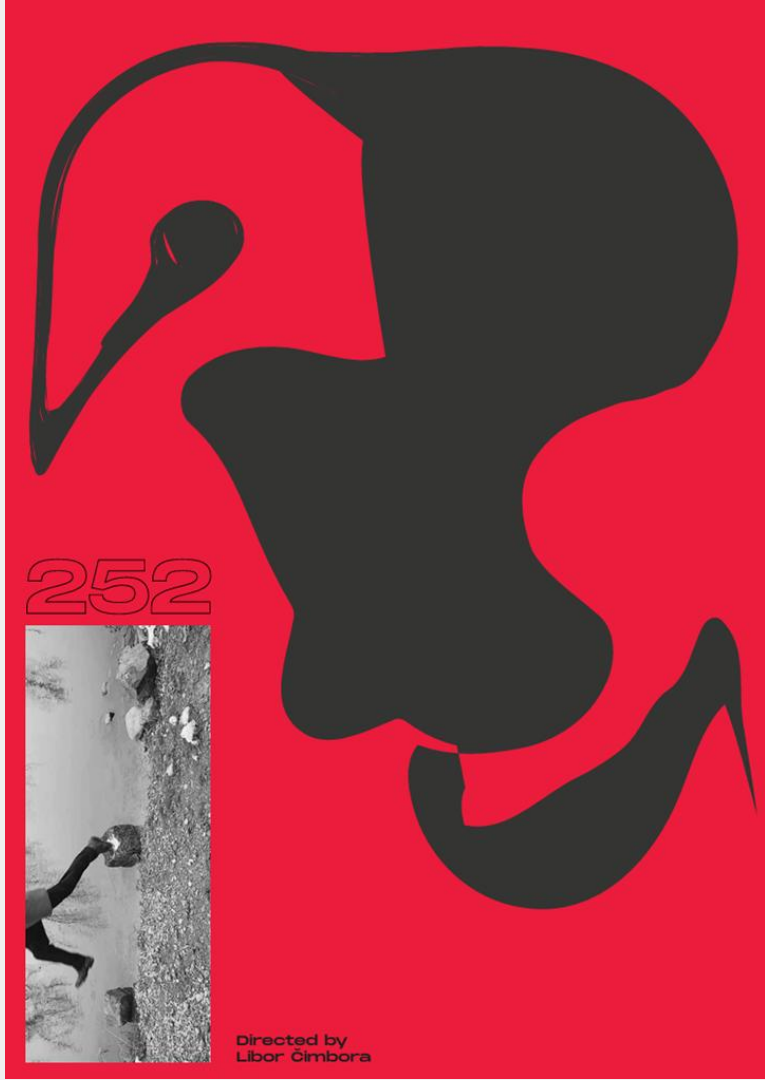



252

252

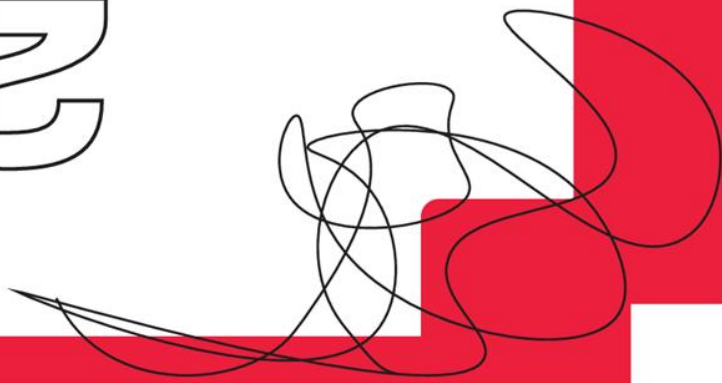

252



Directed by
Libor Cimbara

Ďakujem za pozornosť